

# Stingray

# Hammerhead

300 Hp @ 3,600 Rpm



by  
**Performance Product  
Technologies**

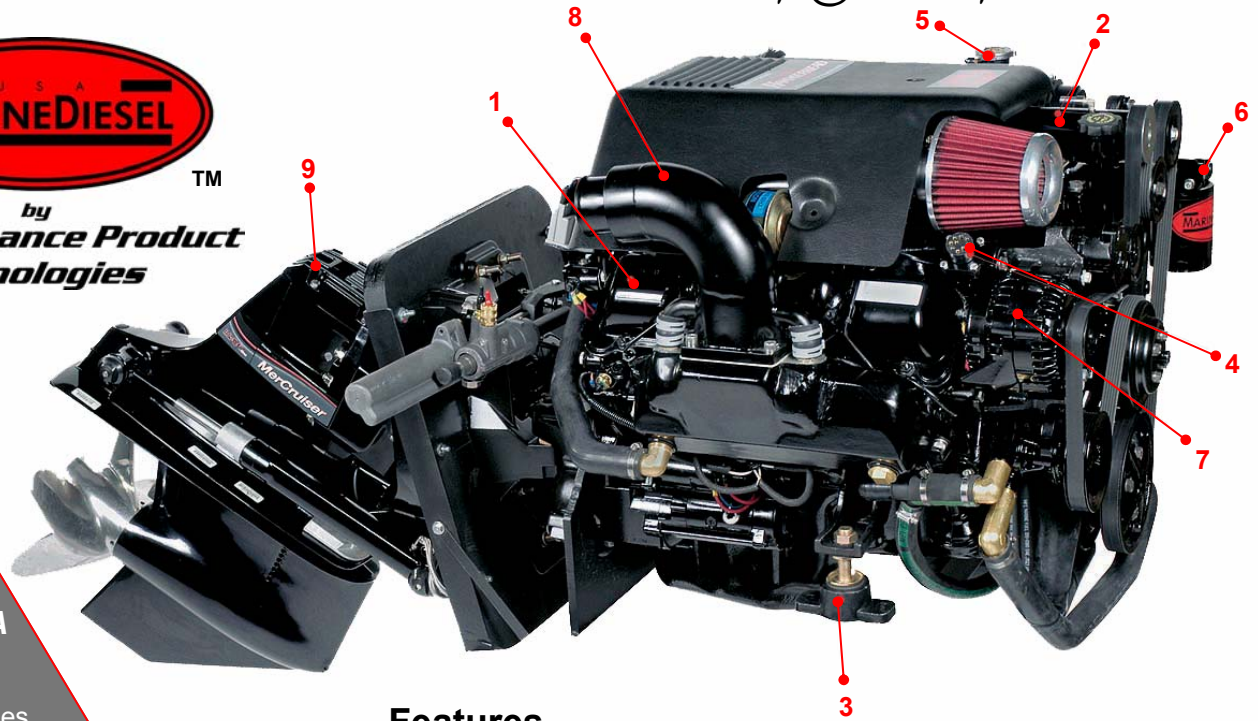

### MarineDiesel-USA

The MD250 & MD300, when joined with MerCruiser's Diesel-X Series sterndrive provides the marine industry with its most impressive combination of diesel engine & outdrive. Only MarineDiesel offers the rugged durability of the Optimizer 6500 packaged with Merc's impressive new Diesel-X sterndrive.

### Technical Data

Displacement..... 6.5L  
 Configuration..... V-8  
 Rated RPM..... 3600  
 Horsepower..... 250 or 300 @ 3600  
 Torque ft. lb..... 460 or 515 @ 1700  
 Bore & Stroke..... 103 X 97mm  
 Compression Ratio..... 18:1  
 Fuel System..... Indirect Injection  
 Aspiration..... Supercharged-Intercooled  
 Alternator..... 12V, 105amp  
 Cooling..... Dual pump w Heat Exchanger

### Size

Length..... 30.7"  
 Width..... 34"  
 Height..... 30.7"  
 Weight less drive pkg..... 948 lbs.  
 Weight with Bravo I pkg..... 1225 lbs.  
 Weight with Bravo II pkg..... 1237 lbs.  
 Weight with Bravo III pkg..... 1246 lbs.

### Features

1. AM General's Optimizer 6500 base engine
2. Ultra-Efficient Lysholm Twin Screw Supercharger
3. Engine Mounts & Bellhousing match GM produced small & big block V8 gas engines
4. Standard MerCruiser / Volvo Penta 9-pin electrical harness connector
5. Hi-Capacity Cu-Ni Heat Exchanger
6. Remote Mounted Oil Filter
7. Hi-Output 105amp Alternator
8. Powder Coated Stainless Steel Dry-Joint Risers with Performance Tuned Aluminum Manifolds
9. Multiple Drive Options—MerCruiser Diesel X Stern-drives

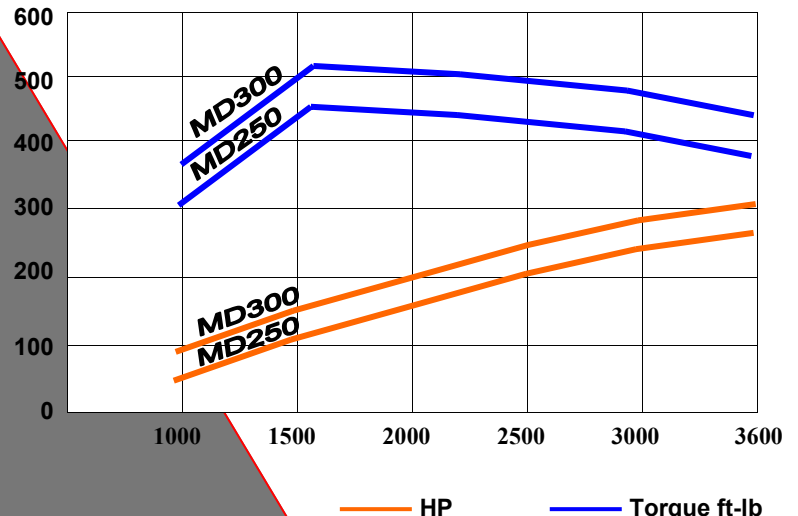

1414 South Sangre Rd.  
 Stillwater, OK. 74074

Ph: 405-533-3833 Fax: 405-377-3388

E-mail: [sales@marinedieselusa.com](mailto:sales@marinedieselusa.com)

# Model's MD250 & MD300

## Direct Replacement

When replacing existing GM small or big block V8 gas engines the MarineDiesel will match the existing mounts, fly-wheel housing, length, width, height and weight to that of existing gas engines, as well as offers a standard 9-pin electrical harness connection to match existing boat harnesses. This allows preserving the original integrity of the boat utilizing mounts, exhaust system, gauges, alarms and tachometers. When comparing competitive products make sure to compare the overall installed engine cost, not just the product cost.

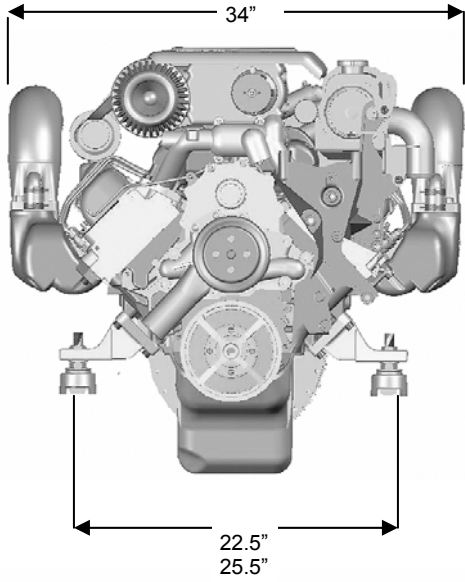
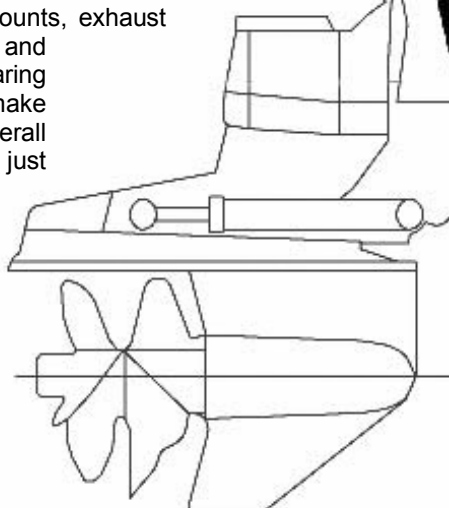

New for 2005 MarineDiesel-USA is proud to announce the addition of the MerCruiser Bravo-X Diesel Series outdrive to our already impressive lineup. The Bravo-X Diesel drives represent a break through in diesel / sterndrive technology and durability.

- The following drive ratio's are available.
- Bravo I ..... 1.36 & 1.5:1
  - Bravo II ..... 1.65, 1.81 & 2.0:1
  - Bravo III ..... 1.5, 1.65 & 1.81:1
  - Jackshaft Kit ..... Optional

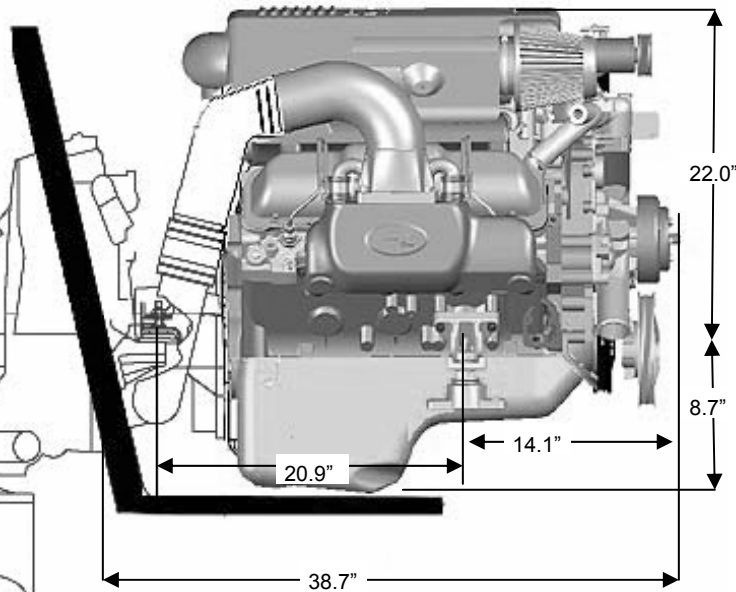

## Performance

Starting with a 6.5L displacement in a V8 configuration, MarineDiesel achieves superior low rpm torque versus smaller displacement inline engines. Adding to this displacement MarineDiesel utilizes a custom low-rpm high torque intercooled supercharging system to achieve incredible low rpm performance.

## Durability

Built on AM General's Optimizer 6500 engine platform this rugged engine is durable enough to be used to power such well known vehicles as the Hummer and military Humvee. With the Optimizer 6500 as a starting place MarineDiesel takes things to a whole new level by adding a performance tuned center riser dry-joint exhaust system with stainless steel risers, a high capacity fresh water cooling system, Lysholm Twin Screw Supercharger with multi-pass cu.ni. Intercooler, 105 amp alternator, oil drain system and fresh water flush kit.

**1414 South Sangre Rd.  
Stillwater, OK. 74074  
Ph: 405-533-3833 Fax: 405-377-3388  
E-mail: [sales@marinedieselusa.com](mailto:sales@marinedieselusa.com)**

All MarineDiesel engines

