

MONITOR PRODUCTS, INC.
15400 Flight Path Dr
Brooksville, FL 34604
Tel: 800-334-4591
Sales: ext 201
TechnicalSupport:ext209 & 210
Fax: 352-544-0870

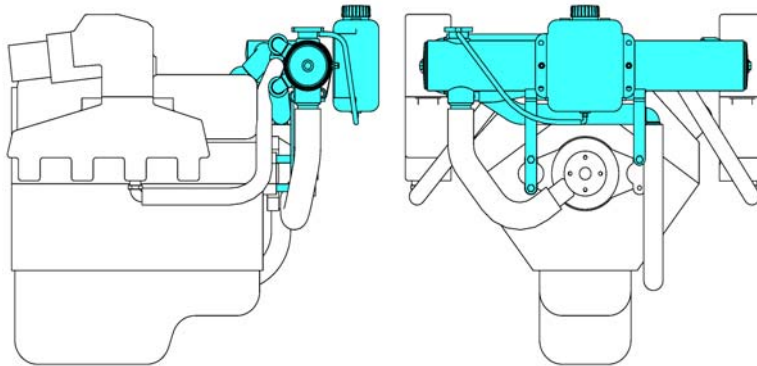

HIGH PERFORMANCE
BIG BLOCK 454-502 CID
FRESHWATER COOLING
KIT SPECIFICATIONS
MFH-5403

MFH-5403 HIGH PERFORMANCE BIG BLOCK BLOCK ONLY FRESHWATER COOLING KIT



CONVERSION KIT FITS:

High performance Chevy based big block V8 engines both sterndrive and inboard. This system requires a raw water pump with a least a 30 gallon per minute (gpm) capacity and a good jacket water pump with at least 60 gpm capacity. The system is front mounted at the level of the thermostat housing and the engine must have the alternator and the power steering pump mounted low as the heat exchanger extends across the full width of the engine. The heat exchanger is 4 1/8" dia. x 29" long. Some engines may require relocating the oil dipstick. Some engines have fuel line routing and fuel filter location that must be changed slightly. See above illustration. Plastic expansion tank mounts either on front of heat exchanger or if space is limited on vertical surface next to engine.

COOLING SYSTEM TYPE

Block only. Engine block on fresh water system. Exhaust manifolds remain on raw water system. System utilizes a new, unique, high performance heat exchanger, with built in, full flow, thermostat with a controlled bypass ensuring optimal jacket water flow under all operating conditions.

CONVERSION KIT

Kit includes heat exchanger, heavy duty translucent plastic expansion tank plus all other components necessary to complete conversion. Heavy duty brackets designed for the higher g-forces most high performance boats experience. Some components from engine are reused. Heat Exchanger and Brackets are unpainted. Hose clamps all stainless steel.

MONITOR PRODUCTS, INC.
15400 Flight Path Dr
Brooksville, FL 34604
Tel: 800-334-4591
Sales: ext 201
TechnicalSupport:ext209 & 210
Fax: 352-544-0870



HIGH PERFORMANCE
BIG BLOCK 454-502 CID
FRESHWATER COOLING
KIT SPECIFICATIONS
MFH-5403

HEAT EXCHANGER

Shell and tube type heat exchanger. Units designed with sealed 6 pass dividers and 151 tube copper bundle to achieve a higher cooling capacity. All copper alloy construction made to the highest industry standards. Heavy-duty cast bronze dual demountable clean-out end covers. Zinc anode protection.

COOLING SYSTEM CAPACITY

System will maintain engine temperature in the 160-170° F range using 160° F controlled by-pass thermostat included on heat exchanger. Controlled by-pass thermostat insures maximum water flow through heat exchanger, when engine is hot, and high flow through by-pass, when engine is warming up to temperature. System has cooling capacity safety margin higher than industry standards.

INSTALLATION TIME

Typical average installation time is approximately 2 -3 hours, assuming new engine and normal accessibility. Allow additional time for filling and testing. Installation skills are not beyond those of most do-it-yourself boat owners. Complete illustrated installation instructions are included in kit. Ordinary hand tools are used.

WARRANTY

Two year warranty. For complete details see Limited Warranty for Fresh Water Cooling Kits document enclosed with your kit and located on policies page of our website.

PRICE

Trade and volume discounts available. Buy through your dealer or direct using Visa, MasterCard, Am Express, UPS COD or money order.