

MFH-5403

High Performance Big Block Block Only Fresh Water Cooling Kit Instructions

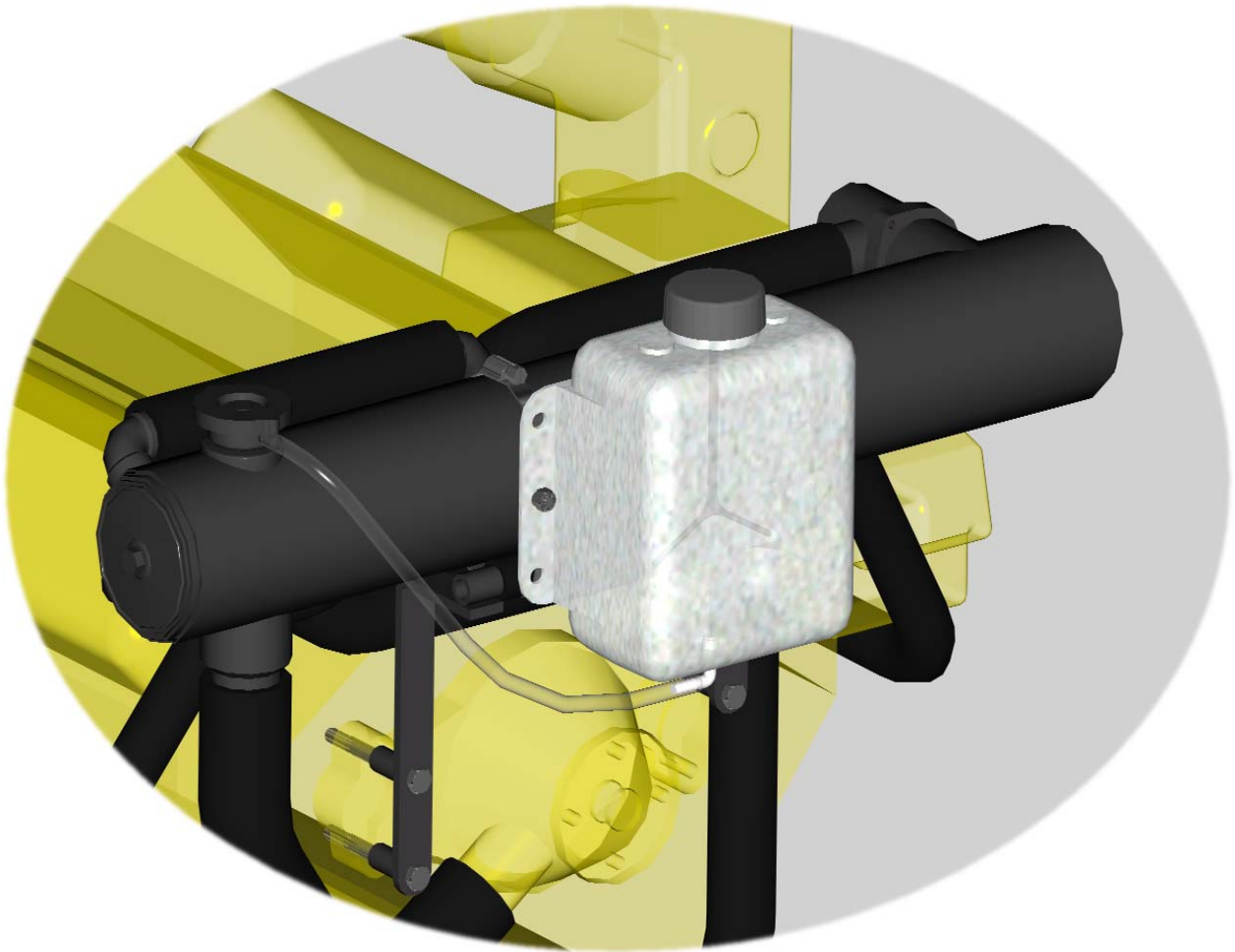

MONITOR PRODUCTS, INC.

15400 Flight Path Dr
Brooksville, FL 34604

Tel: 1-800-334-4591 or 352-544-2620

Sales: ext 201

Technical Support: ext 209

Fax: 352-544-0870

IMPORTANT

Before you unpack the kit and start installation, make sure you have the right kit for your engine by studying these installation instructions. These installation instructions have been written to cover most sterndrive and inboard installations on high performance Chevy big block engine conversions. The system is front mounted at the level of the thermostat housing and the engine must have the alternator and the power steering pump mounted low as the heat exchanger extends across the full width of the engine. The heat exchanger is 29" long. Some engines may require relocating the oil dipstick.

These instructions cover a normal installation situation. Sometimes problems can occur due to engine variations and boat-builder or owner modifications. If you run into such problems you can call Monitor Products for advice during normal business hours.

If you determine this is the wrong kit for your type of engine:

- Call the distributor you purchased the kit from for their return policy.
- If you purchased the kit from Monitor Products Inc., call 1-800-334-4591 for a return authorization. No returns will be accepted without this authorization. The kit must be in new condition and repacked in its original packaging to qualify for credit or replacement.

MONITOR PRODUCTS, INC.

1-800-334-4591

Tel: 352-544-2620

Customer Service: ext 201

Technical Support: ext 209

Fax: 352-544-0870

The installer must make sure that the overall installation is safe and in accordance with Coast Guard and industry standards.

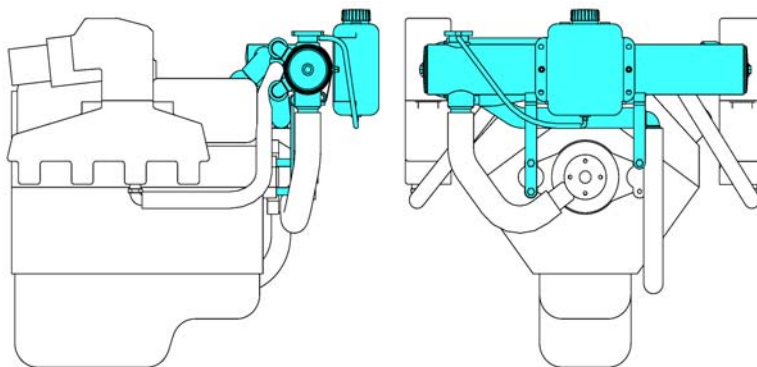

Installation tools & supplies

Flat head screw driver
Phillips head screw driver
11/16" deep socket or box wrench
9/16" socket or box wrench
7/16" socket or box wrench
3/16" hex key

7/32" hex key
Hose Cutter or Knife
Gasket scraper
RTV silicone gasket sealer
Antifreeze solution (See flush and fill instructions)

Items included in kit:

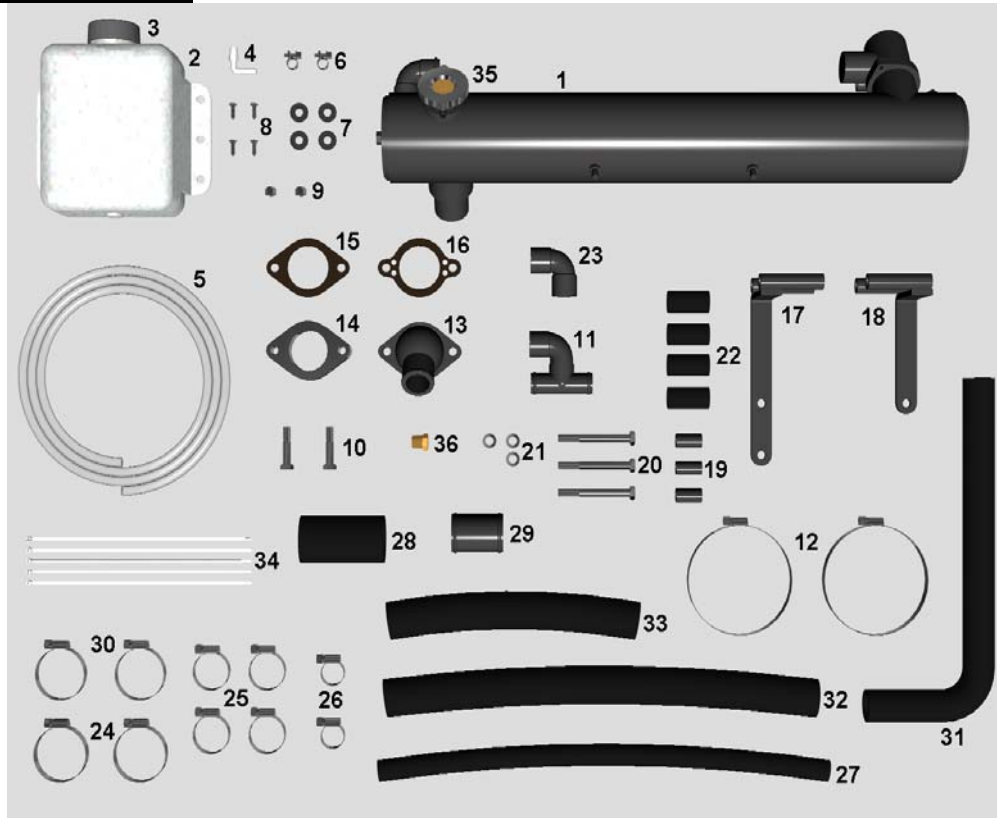

Item	Qty.	Part Number	Description	Item	Qty.	Part Number	Description
1	1	M5403-4256	Heat Exchanger	19	3	0506-2103	1 1/4" Spacer
2	1	5001-1327	Expansion Tank	20	3	4300-2998	3/8-16 x 3 1/2" Bolt
3	1	5000-1763	Cap, Expansion Tank	21	3	4300-1386	3/8" Lock Washer
4	1	5000-1343	1/8" NPT x 5/16" Hose Adapter	22	4	5102-2124	Isolators
5	1	5102-2125	5/16" ID x 48" PVC Hose	23	1	3108-1202	1 1/4" 90° Hose Coupling
6	2	5200-1344	Mini Clamp #02	24	2	5200-1143	Hose Clamp #24
7	4	4300-2802	5/16" Washer	25	4	5200-1144	Hose Clamp #16
8	4	4300-2801	#12 x 3/4" Flat Head Screw	26	2	5200-1401	Hose Clamp #12
9	2	4300-2790	5/16-18 Nylon Locking Nut	27	1	5109-2128	5/8" ID x 22" Hose
10	2	4300-1575	3/8-16 x 2" HHCS	28	1	5104-2129	1-3/4" ID x 4" Hose
11	1	5000-3038	Raw Water Splitting Tee	29	1	0321-2100	1-3/4" Hose Coupling
12	2	5200-1610	Hose Clamp #72	30	2	5200-1475	Hose Clamp #28
13	1	5000-1281	Water Outlet	31	1	5100-1290	1-1/2" ID x 14" x 6-1/2" Hose
14	1	4006-2003	Water Outlet Spacer	32	1	5109-2134	1 1/4" ID x 21" Hose
15	1	4500-1381	Water Outlet Gasket	33	1	5108-2134	1 1/4" ID x 12" Hose
16	1	4500-3004	Grounded Water Outlet Gasket	34	5	5000-1154	Tie Wraps
17	1	5000-2992	Bracket, Big Block, Left	35	1	4000-1857	Pressure Cap 16#
18	1	5000-2993	Bracket, Big Block, Right	36	1	4400-1314	3/8" NPT Plug

Installation Steps

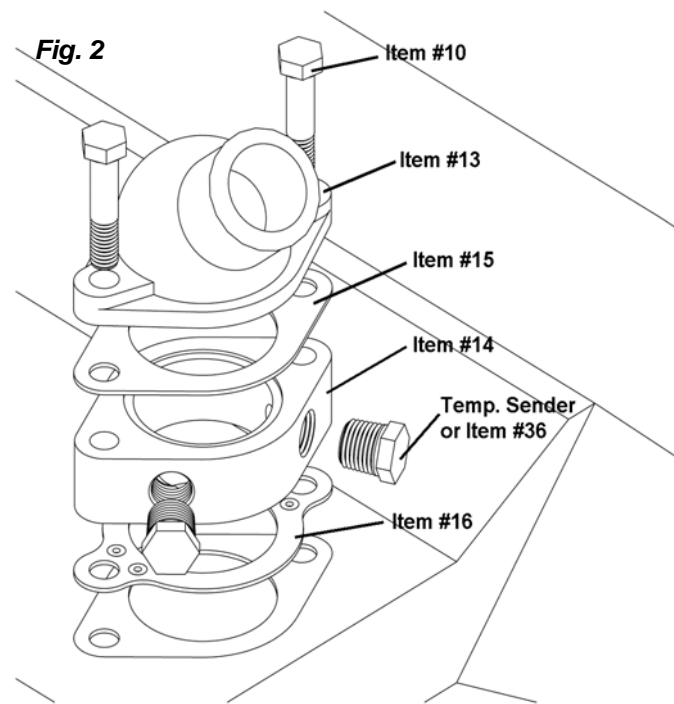
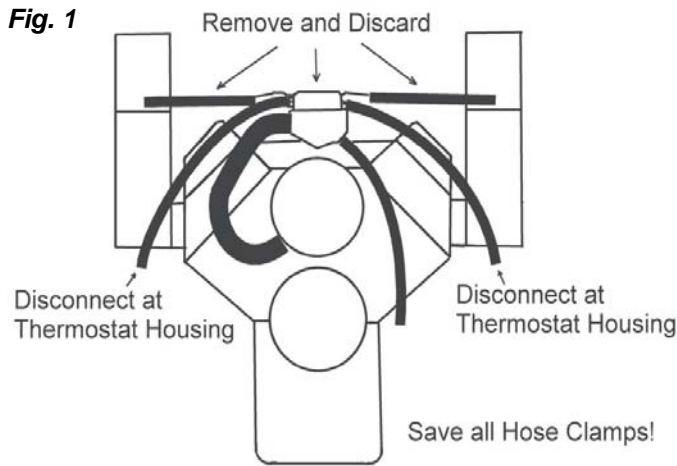

1. Drain water from block by removing plugs from both lower sides of engine.
2. Remove hoses from the existing thermostat housing. Save all hose clamps. See Fig. 1.
3. Disconnect wires from temperature sender(s) and remove the sender(s) from thermostat housing.
4. Remove and discard existing thermostat housing, thermostat, gasket and bolts. Scrape surface clean especially grooves where new thermostat will be located. Avoid getting scrapings into thermostat opening. See Fig. #1
5. Flush engine. If new, flush engine briefly with fresh water through thermostat opening. Use a garden hose with a rag around it. If used, more thorough flushing may be needed. See Flushing instructions in Fresh Water Cooling General Maintenance Manual.
6. Install water outlet spacer (Item #14), and water outlet (Item #13), with two gaskets (Item #15 and Item #16) using two 3/8-16 x 2" bolts (Item #10) as shown in Fig. #2. Tighten 3/8-16 bolts securely.
7. Thread temperature sender into spacer. If overheat alarm is used, thread into the other threaded hole of spacer. If not, install 3/8" plug (Item #36). Reconnect wire to temp senders. We strongly recommend that you install an audible "buzzer" type alarm. These overheat alarms are usually combined with low oil pressure alarm and are very reasonable in price.

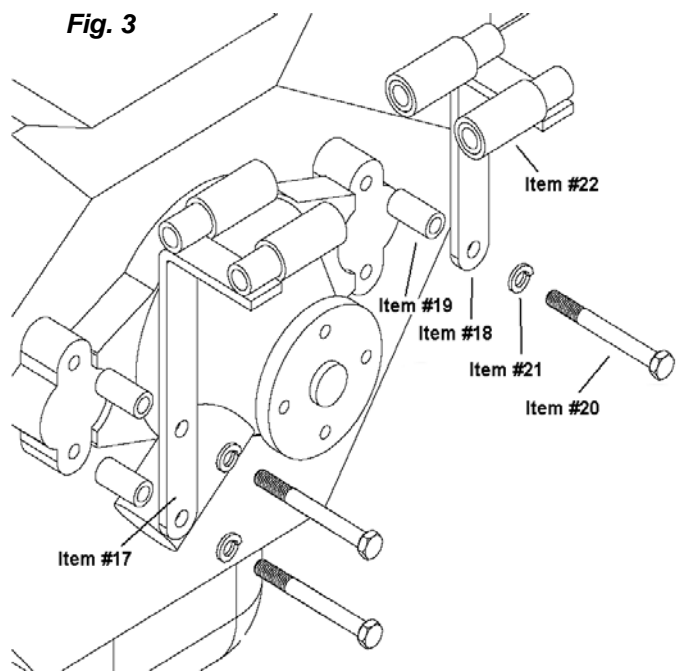

8. Install left bracket (Item #17) to front of jacket water pump by removing bolts from left side of water pump and installing the bracket with two spacers (Item # 19) using 3/8"-16 x 3 1/2" bolts (Item # 20) and lock washers (Item # 21). See Fig. # 3.
9. Install right bracket (Item #18) to front of jacket water pump by removing top bolt from right side of water pump and installing the bracket with a spacer (Item #19) using 3/8"-16 x 3 1/2" bolt (Item #20) and lock washers (Item #21). Be sure that when heat exchanger is installed it will not interfere with any belts, fuel lines, or hatches and covers. See Fig. # 3.

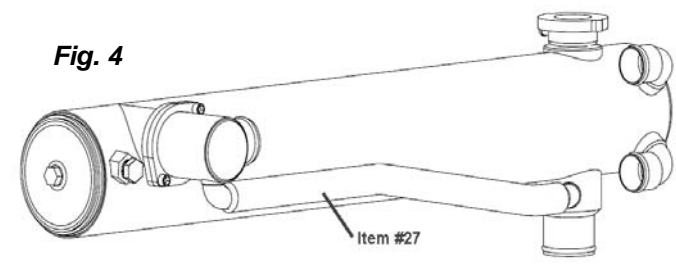

10. Install isolators (Item #22) onto bracket rails.
11. Install 5/8" ID x 22" hose (Item #27) from 5/8" fitting on heat exchanger to 5/8" fitting on thermostat housing, using two #12 hose clamps (Item #26). See Fig. # 4.

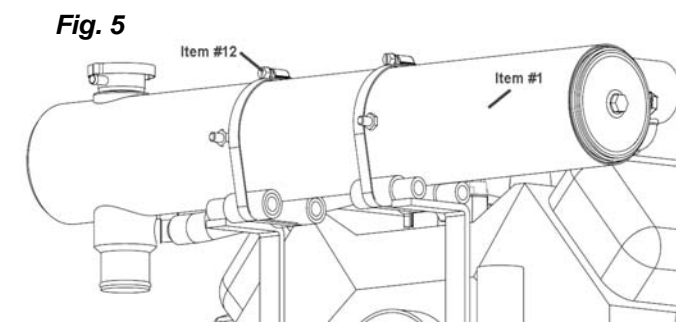

12. Install heat exchanger (Item #1) on rails of bracket and secure with two large hose clamps (Item #12). See Fig. # 5.

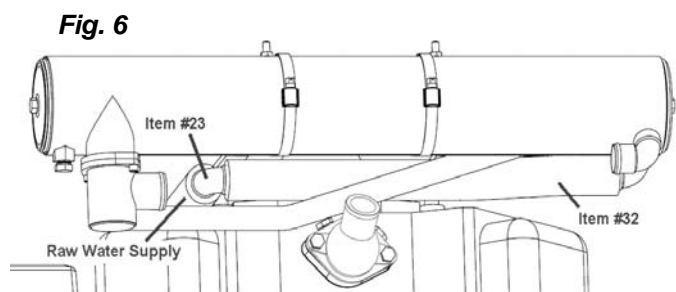

13. Install the 90° hose coupling, (Item #23) into raw water supply hose using existing clamp. Supply hose may need to be trimmed. Measure, between the 90° hose coupling and the 1 1/4" raw water inlet on the heat exchanger, and cut 1 1/4" ID hose (Item #32) to length. Trim hose as required to fully engage both fittings. Secure using two hose clamps (Item #25). See Fig. # 6.

Fig. 7

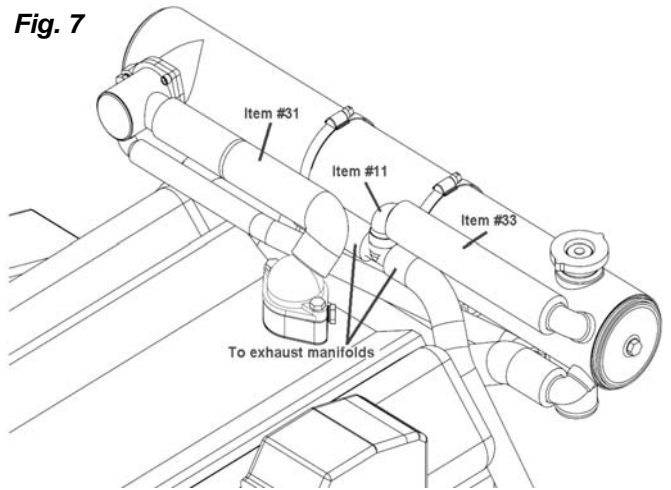

The expansion tank, that comes with this system, is more than an overflow bottle. It is a critical part of the cooling system that must be installed. Water will be pushed into and drawn from the tank as part of the normal operation of the cooling system

Fig. 8

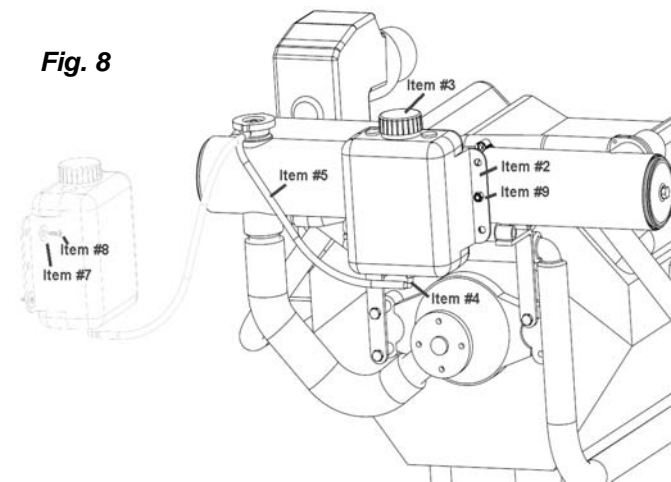

14. Connect raw water splitting tee (Item #11) to heat exchanger at top rear left side of heat exchanger with 1 1/4" ID hose (Item #33) using clamps (Item #25).

15. Attach hoses leading to bottom or front of exhaust manifolds to each side of tee assembly. Use existing hose clamps. See Fig. #7.

16. Connect heat exchanger to water outlet with 1 1/2" ID molded hose (Item #31) using clamps (Item #24). See Fig. #7.

17. Trim 1 3/4" molded hose running from circulating pump to engage 1 3/4" fitting on heat exchanger. Secure using existing clamps. See Fig. # 4. (If needed, use 1 3/4" hose coupling (Item #29), 1 3/4" hose (Item #28), and hose clamps (Item #30) to make this connection.)

18. Thread plastic elbow (Item #4) into bottom of expansion tank (Item #2) using sealer. cap (Item #3) should already be in place. See Fig. #8.

19. Mount Expansion tank on studs on front of heat exchanger using 5/16-18 nylon locking nuts (Item #9). If space in front of engine does not allow installation on heat exchanger, install on vertical surface next to engine using washers (Item #7) and screws (Item #8). Keep as close to engine as is practical, with top of tank at the same level as the top of heat exchanger.









The exact level of the expansion tank is not critical. If the tank is higher than the heat exchanger it is necessary to pinch tubing shut whenever pressure cap is removed or system will overflow. If mounted excessively low it is IMPORTANT that the upper rubber gasket of the pressure cap seals perfectly or system may draw air back instead of coolant when the system contracts due to cool down.

20. Connect 5/16" clear PVC hose (Item #5) to the fitting on filler neck and elbow on bottom overflow bottle with mini clamps (Item #6).

We strongly recommend that you install an audible "buzzer" type alarm. These overheat alarms are usually combined with low oil pressure alarm and are very reasonable in price.

21. Use tie wraps (Item #34) to make sure that hoses or other parts are not in contact with critical engine components, such as belts and fuel lines.
22. Reinstall engine block drain plugs.
23. Double check total installation and make sure all fasteners, fittings, and hose clamps are tightened properly. See Filling and Start-Up Instructions in Fresh Water Cooling General Maintenance Manual.

Replacement Parts

	Part Number	Description
	5000-1763	Cap, Expansion Tank
	4000-1857	Pressure Cap, 16# SS
	5000-1709	Thermostat 160° W/ Control
	4500-1381	Gasket, Water Outlet
	4500-1622	Gasket, Rubber Thermostat
	4500-3004	Grounded Water Outlet Gasket
	4500-1082	O-Ring, Buna-N
	4500-2005	Gasket, 4" (end cover)
	4400-1044	Zinc Anode, 3/8"NPT, 1-1/4" Long