

MFH-5230 Fresh Water Cooling Kit Instructions



MONITOR PRODUCTS, INC.

15400 Flight Path Dr

Brooksville, FL 34604

Tel: 352-544-2620 Sales: ext 201

Technical Support: ext 209

Fax: 352-544-0870

IMPORTANT

Before you unpack the kit and start installation, make sure you have the right kit for your engine by studying these installation instructions. This system is for use with late model Mercury engines only. The system is front mounted at the level of the thermostat housing and the engine must have the alternator and or the power steering pump mounted low or to the extreme port side of the engine. The heat exchanger is flush with the extreme starboard side of the engine and this kit is, therefore, not suitable for V-drive engines. This kit is intended for both the V-belt and serpentine belts. Kit MFH 5230 will not work with fuel injection.

These instructions cover a normal installation situation. Sometimes problems can occur due to engine variations and boat builder or owner modifications. If you run into such problems you can call Monitor Products for advice during normal business hours. The phone number is 1-800-334-4591.

If you, by mistake, received the wrong kit for your type of engine or run into other insurmountable installation problems you may return an undamaged kit for exchange or credit. To get return authorization, call Monitor Products with information about the problem and how the kit was purchased.

The installer must make sure that the overall installation is safe and in accordance with Coast Guard and industry standards.

NOTE: Engines equipped with remote mounted oil filters must use Relocation kit 4000-1849 supplied.

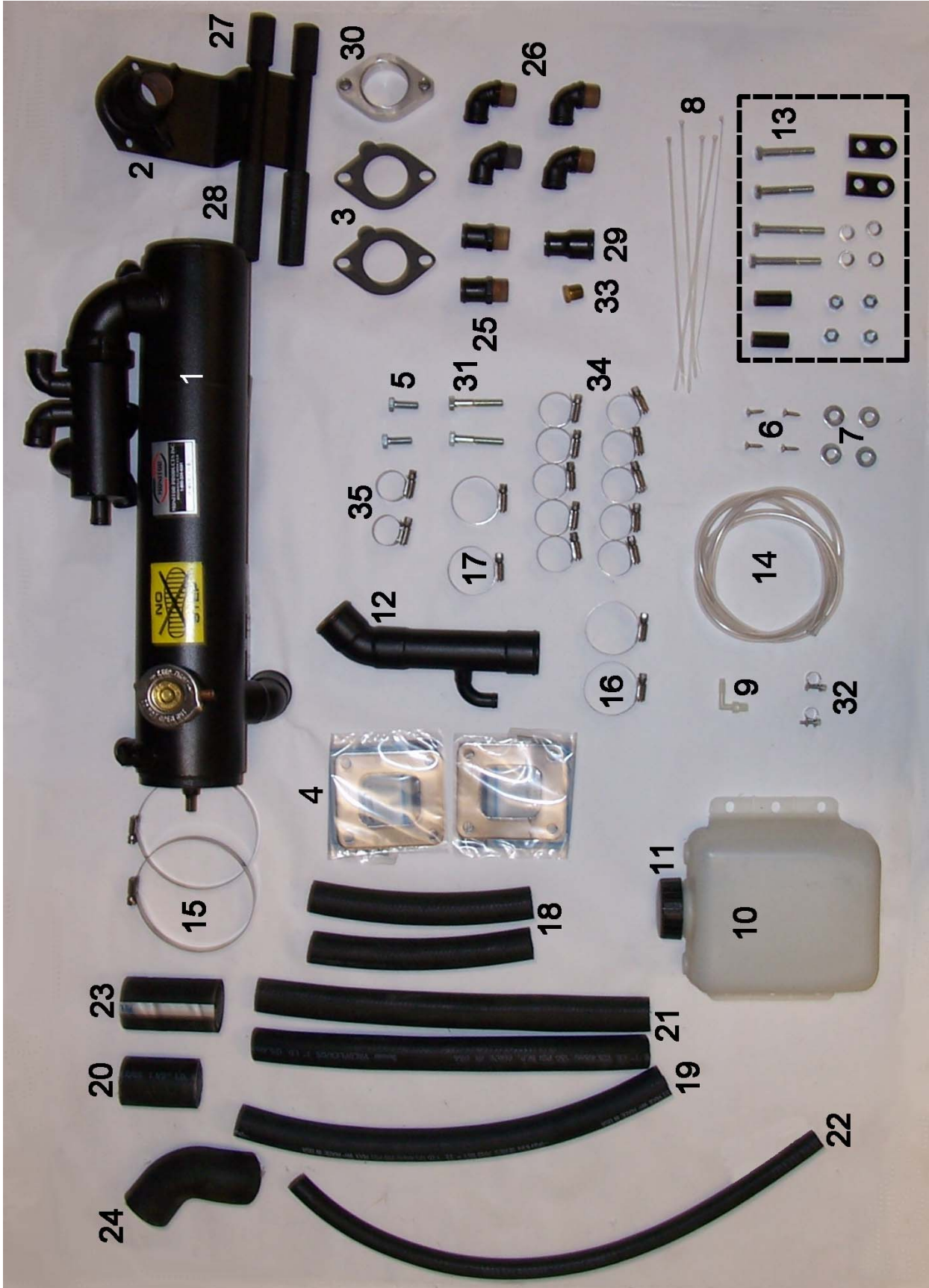

Parts List

<u>Item Number</u>	<u>Part Number</u>	<u>Quantity</u>	<u>Description</u>
1	M5230-4176PC	1	HEAT EXCHANGER, POWDER COATED
2	5001-1971PC	1	BRACKET ASSY, POWDER COATED
3	4500-1381	2	GASKET, THERMOSTAT HOUSING
4	4500-1824	2	GASKET, BLIND (EXHAUST ELBOW)
5	4300-1138	2	HHCS, 3/8-16 x 1, ZP, GRADE 5
6	4300-2801	4	SCREW, #12 PHILLIPS FLAT HEAD x .75
7	4300-2802	4	WASHER, 5/16, FLAT
8	5000-1154	5	TIE WRAPS, PLASTIC 10"
9	5000-1343	1	ADAPTER, ELBOW PLASTIC, 1/8 x 5/16"
10	5001-1327	1	TANK EXPANSION, 3QT, MODIFIED
11	5000-1763	1	CAP, EXPANSION TANK, 2-1/4 VENTED
12	5001-1992PC	1	TUBULAR CONN ASSY BLACK
13	4000-1849	1	OIL FILTER RELOCATION KIT FULL SYSTEM MF
14	5102-2125	1	HOSE, PVC, 5/16 x 48"
15	5200-1610	2	CLAMP, HOSE #72, 4-1/8 x 5, BR
16	5200-1475	2	CLAMP, HOSE #28, 1-1/16 x 2 1/8
17	5200-1143	2	CLAMP, HOSE #24, 1-1/16 x 2, BR
18	5102-2126	2	HOSE 1 x 9"
19	5111-2126	1	HOSE 1 x 18"
20	5102-2127	1	HOSE 1 1/2x3"
21	5108-2126	2	HOSE 1 x 16"
22	5110-2128	1	HOSE HEATER 5/8x24"
23	5101-2129	1	HOSE 1 3/4x 3.75"
24	5101-1996	1	HOSE, MOLDED GDYR#60197 CUT
25	5000-1980PC	2	FITTING, EXHAUST STRAIGHT
26	5000-1979PC	4	FITTING, EXHAUST ELBOW
27	5102-2124	2	HOSE, HEATER, 3/4 X 2"
28	5105-2124	2	HOSE HEATER 3/4 x 4"
29	3202-1140PC	1	COUPLING 1x3/4 BEAD-POWDER COATED
30	4003-2003	1	THERMOSTAT HOUSING SPACER W/C'BORE
31	4300-1575	2	HHCS, 3/8-16 x 2, ZP, GRADE 5
32	5200-1344	2	CLAMP, SMOOTH BAND SS MINI, 23/64 X 29/64
33	4400-1314	1	DRAIN PLUG, 3/8 NPT"
34	5200-1144	10	CLAMP, HOSE #16, 3/4 x 1-1/2, BR
35	5200-1401	2	CLAMP, HOSE #12, 5/8 x 1-1/4

Installation Steps

1. Drain block by removing plugs from both lower sides of engine.
2. Remove temperature sensors and place them on the side for use later.
3. Remove all hoses running to thermostat housing. Discard large hose running to circulating pump. Save all clamps. See Fig. 1.

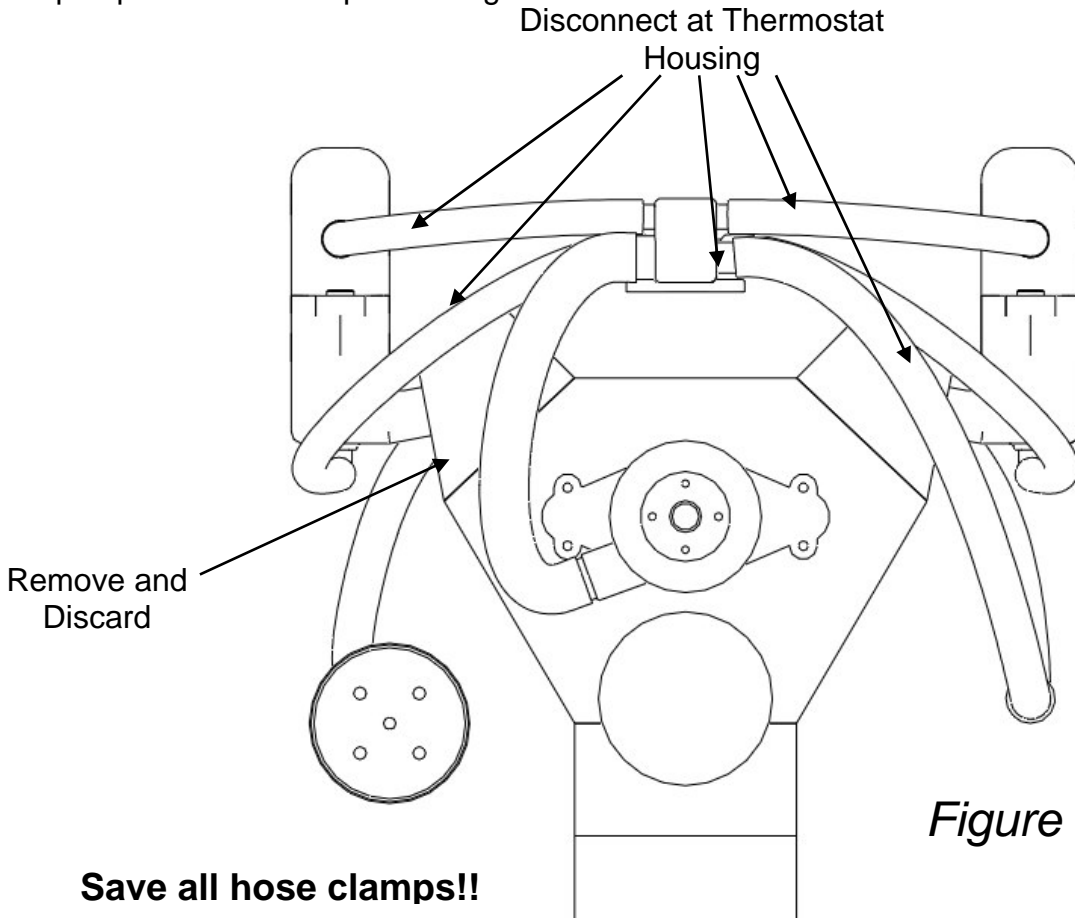

Save all hose clamps!!

4. Remove and discard existing thermostat housing, thermostat, gasket and bolts. Scrape surface clean. Avoid getting scrapings into thermostat opening.
5. Flush engine. If new, flush engine briefly with fresh water through t'stat opening. Use a garden hose with a rag around it. If used, more thorough flushing may be needed.
6. Remove plugs directly in front of mounting studs for exhaust elbows. (1/2" breaker bar and penetrating oil may help) Remove exhaust elbows. Scrape gasket surface clean ensuring nothing falls into ports. If your oil filter is remotely mounted, this is the time to remove it and set it aside.
7. Thread, using sealer, 90° elbow assembly (Item #26) into openings on top of exhaust manifolds (port & starboard) insuring they point toward thermostat opening. Be sure to thread in 90°

elbow assembly (Item# 26) completely. Thread straight fittings (Item #25) into exhaust elbow on both sides.

8. Install manifold gaskets (blind), (Item #4), and reinstall exhaust elbows tightening evenly using torque wrench to 30-35 ft lbs. A good seal here is critical and we recommend you have a pressure test done prior to starting the engine.
9. Install support bracket using 3/8 x 1" bolts, (Item #5) and gasket (Item #3). Install four pieces of 3/4" ID hose, (Item #'s 27 & 28) onto ears of support bracket, (Item #2). It is important to use RTV silicone sealer on both sides of gaskets as well as on the bolts. ***NOTE: If your engine is a 1998 model or newer you will also need to install a 1" spacer (Item #30) to avoid interference between the exchanger and the serpentine belt. The purpose of the spacer is to raise the bracket since the newer intake manifolds are lower. An additional thermostat gasket and 2 3/8 x 2" bolts (Item #31) are included for this purpose.***
10. Install hose 1-1/2" x 3", (Item #20), onto fitting on support bracket. Secure with clamp (Item #17).
Note: Hoses may need to be trimmed to ensure a proper fit.
11. Place heat exchanger onto bracket. Install 45° molded hose, (Item #24), on circulating pump with clamp (Item #16) and leave loose. Install tubular assembly, (Item #12), from circulating pump to exchanger using clamp (Item #16). Reinstall straight hose from copper assembly (Item #12) to exchanger using hose (Item #23) and two clamps (Item #16). Install hoses running from bottom of exhaust manifolds onto fittings that are on the lower side of thermostat housing. Secure all hose connections with existing clamps.
12. Secure heat exchanger to ears of support bracket with two clamps (Item # 15).
13. Install 1" x 18" hose (Item #19) between starboard 90° elbow assembly and elbow on top rear of thermostat housing. Secure with 2 clamps (Item #34). Install 1" x 9" hose, (Item #18), between straight fitting on exchanger to straight fitting assembly on the starboard exhaust elbow using two clamps (Item #34).
14. Install 1"x 16" hose, (Item # 21), between port 90° elbow assembly and elbow on top rear of thermostat housing. Secure with 2 clamps (Item # 34). Install 1"x16" hose, (Item # 21), from straight fitting, port side of heat exchanger, to the straight fitting assembly on the port side exhaust elbow. Secure with clamps, (Item # 34).
15. Tighten clamp, (Item #16), around upper end of 1-1/2" hose, (Item #20) at thermostat housing of heat exchanger. See Fig. 4 for fresh water hose routing.

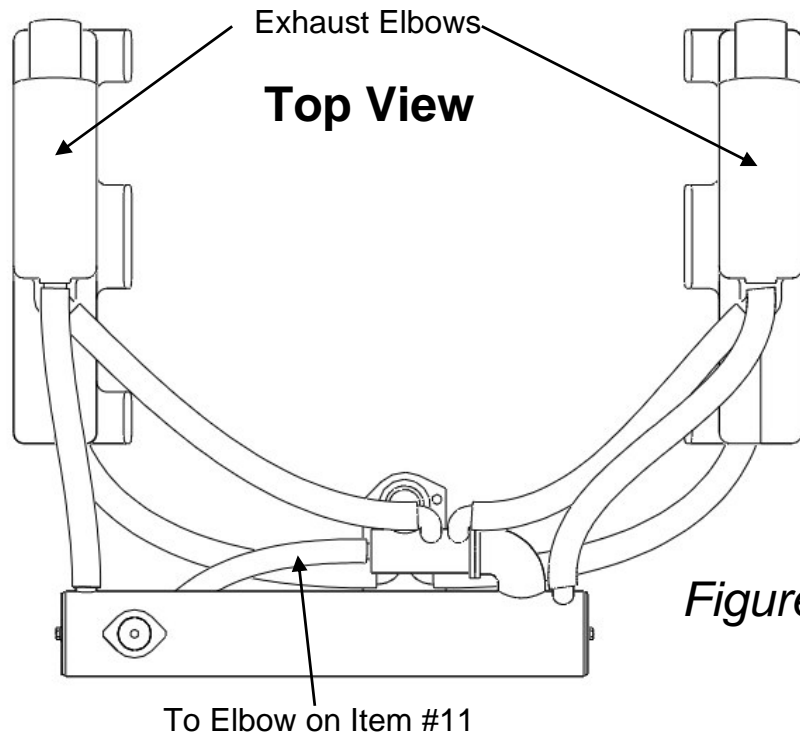

Figure 4

16. Install temperature senders into heat exchanger bracket. These fittings are 3/8" NPT - there is no room for adapter bushings. Therefore, 3/8 NPT sensors must be used.
17. If temperature senders were not in thermostat housing originally, install 3/8 NPT plug (Item #33).
18. Install 5/8 x 24 hose, (Item #22), between thermostat housing and elbow on copper hose assembly. Secure with two clamps (Item #35).
19. Locate 1 1/4 raw water inlet hose (running vertically along front port side of engine), and insert reducer coupling (Item #29). Insert 1"x 9" hose (Item #18) so that it can be installed on elbow hose bib on lower starboard side of exchanger. Trim to fit & tighten with existing clamp and one additional clamp (Item #34).
20. See instructions on oil filter relocation kit assembly, (Item #13).
21. Thread plastic elbow, (Item #9), into bottom of expansion tank, (Item #10), using sealer.
22. This system does not have provisions for an on engine mounted expansion tank. Install on vertical surface, keeping as close to the heat exchanger as is practical with top of tank level with top of exchanger, using screws & washers (Items #6 & #7). Connect to filler neck with 5/16 clear PVC hose, (Item #14) and two clamps (Item #32). Trim hose to fit.
23. Use tie wraps, (Item #8), to make sure that hoses or other parts are not in contact with critical

engine components such as V-belt/serpentine belt and fuel lines.

24.Reinstall engine block drain plugs.

25.Double check total installation and make sure all fasteners, fittings, and hose clamps are tightened properly. See separate Filling and Start-Up instructions.

26.We strongly recommend that you install an audible "buzzer" type alarm. These overheat alarms are usually combined with low oil pressure alarm and are very reasonable in price. Be sure that they are 3/8 NPT.

REPLACEMENT PARTS

<u>PART NUMBER</u>	<u>DESCRIPTION</u>
5000-1763	Cap, expansion tank, 2-¼ vented w/tee
4000-1857	Pressure cap, 16# SS
5000-1709	Thermostat with control
4500-1381	Gasket, thermostat housing
4500-1622	Gasket, rubber thermostat
4500-1082	O-Ring, Buna-N
4500-2005	Gasket, 4" (end cover)
4400-1044	Zinc Anode, 3/8NPT, 1-1/4" Long

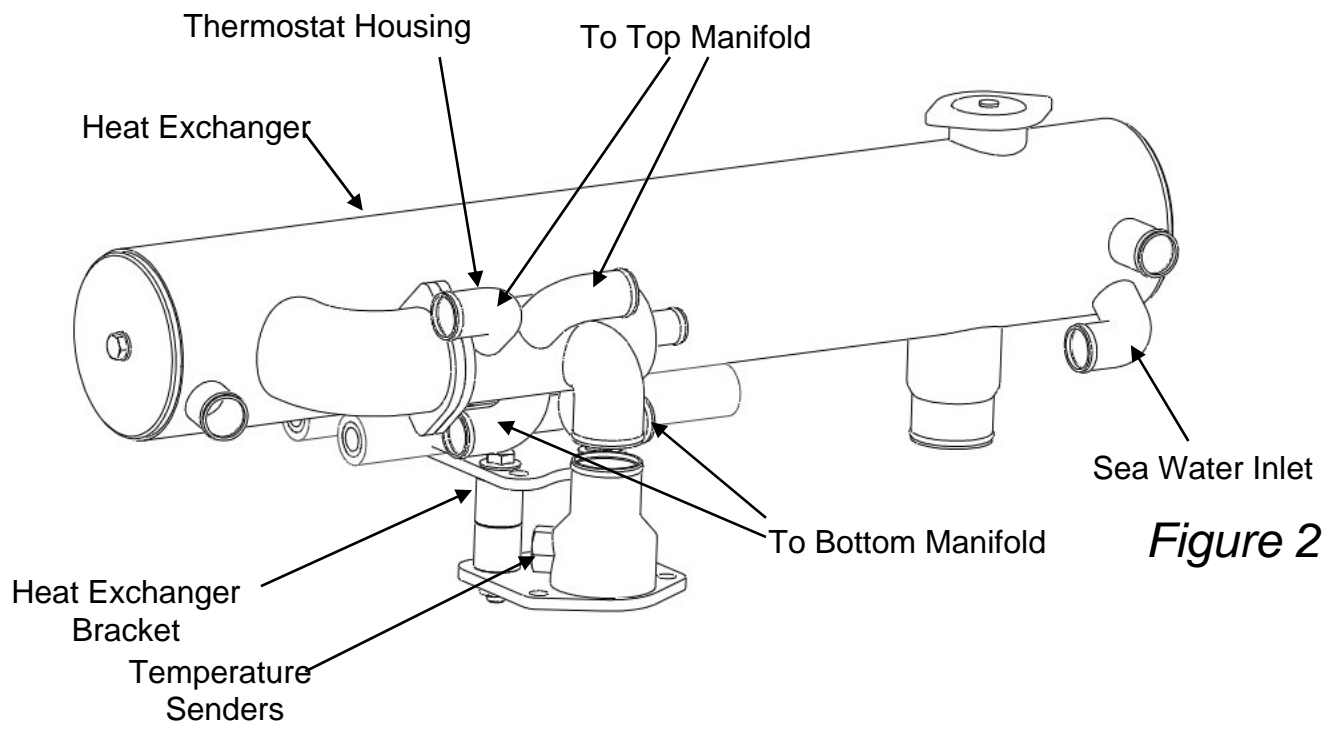

Figure 2

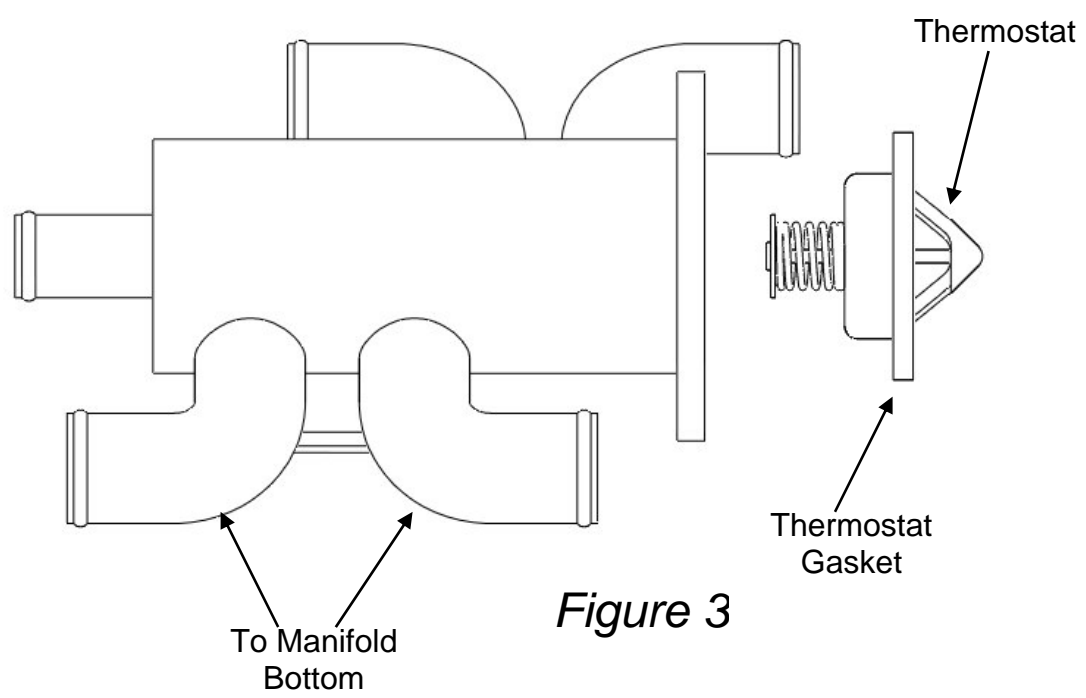

Figure 3

OIL FILTER RELOCATION KIT ASSEMBLY INSTRUCTIONS USED WITH MFH-5230

- If studs are used to fasten exhaust elbows, use the original nuts to secure the oil filter relocation spacer and bracket as shown in **Figure A**.
- If bolts are used, discard original hardware. Then fasten spacer and bracket with 2-3/4" bolts supplied.
- Use 2-1/4" bolts to fasten oil filter bracket into relocation bracket. Then, position the bolts so that the heads of the bolts are facing downward. **See Figure A**.
- Use the 3/8" lock washers and nuts supplied and tighten securely.
- Recheck all instructions.

OIL FILTER RELOCATION KIT PARTS (4000-1849)

<u>QTY</u>	<u>PART#</u>	<u>DESCRIPTION</u>
2	0505-2103	Spacers 1 1/2 x 5/8 OD
2	5000-2499	Bracket 1/4 x 1 x 2
2	4300-1851	Bolts 3/8-16 x 2 1/4
2	4300-1852	Bolts 3/8-16 x 2 3/4
2	4300-1280	Nuts 3/8-16
2	4300-1386	Lock Washers 3/8

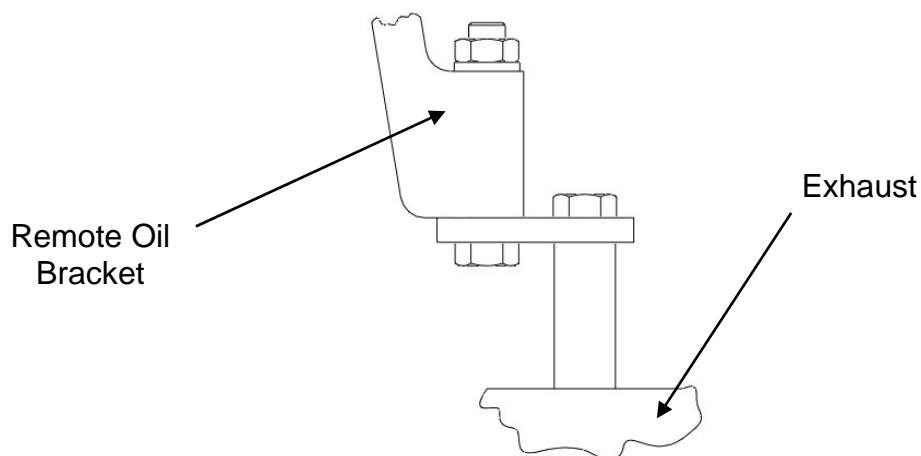

Figure A